



# **OPERATION INSTRUCTION**

## **Video intercom system**

Outdoor Camera

User Manual

# 1. OVERVIEW

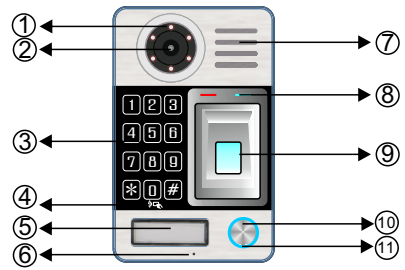

①	IR-LED	1: daytime, color mode, IRLED off; 2: night: black and white mode, IRLED is lit
②	camera	Wide angle camera
③	keyboard	Password unlock keyboard, refer to the actual panel
④	RFID card	Support ISO/IEC 14443 (13.56MHz); the card area is at the keyboard position Reference actual panel
⑤	Nameplate	You can write the user name on it.
⑥	MIC	Sound collection
⑦	Speaker	Sound output
⑧	Fingerprint LED	Fingerprint system working status indicator, please refer to the actual panel
⑨	Fingerprint collection	Semiconductor fingerprint acquisition area
⑩	Call-KEY	Call indoor unit button
⑪	Status Indicator	1: Standby: blue 2: Work: Red

Some products have this function:  
 Press and hold for 5 seconds.  
 This button can switch the mode of  
 the camera output: 1080P-720P-CVBS.  
 It will be successful after power on again.

Note: Whether there are 2 or 3 please refer to the physical panel

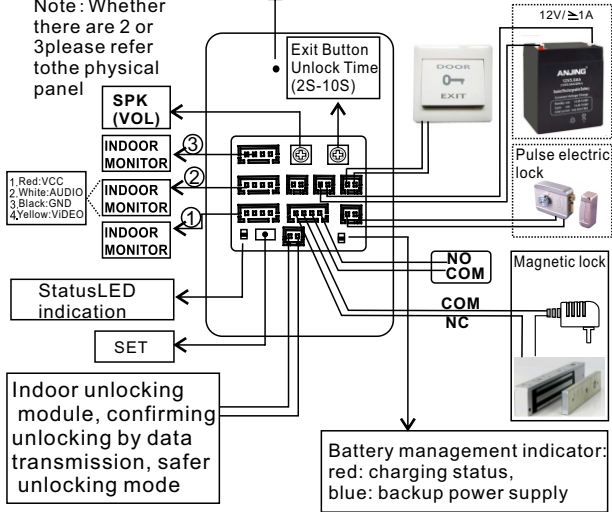

Note: Please refer to the actual panel for actual functions and number of users. The connected interface terminals correspond to the number of users

## 2. Installation diagram

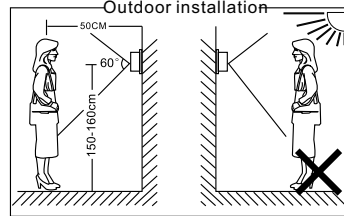
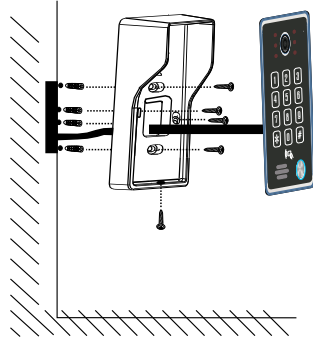

### NOTE:

- Do not install the call panel in this environment e.g. direct sunlight, contact rain, High temperature, high humidity, full of dust and chemistry corrosive
- Switch off power supply before installation.
- Keep more than 30cm away from AC power supply to avoid external interference

### Installation process :

- 1: First drill the hole in the wall, For routing
- 2: Drill 4 6mm holes for mounting the swell plastic
- 3: Fix the rain cover on the wall and fix the 4PCS screws
- 4: Connect the wires according to the instructions
- 5: Fix the lower screw

### 3. Machine software architecture

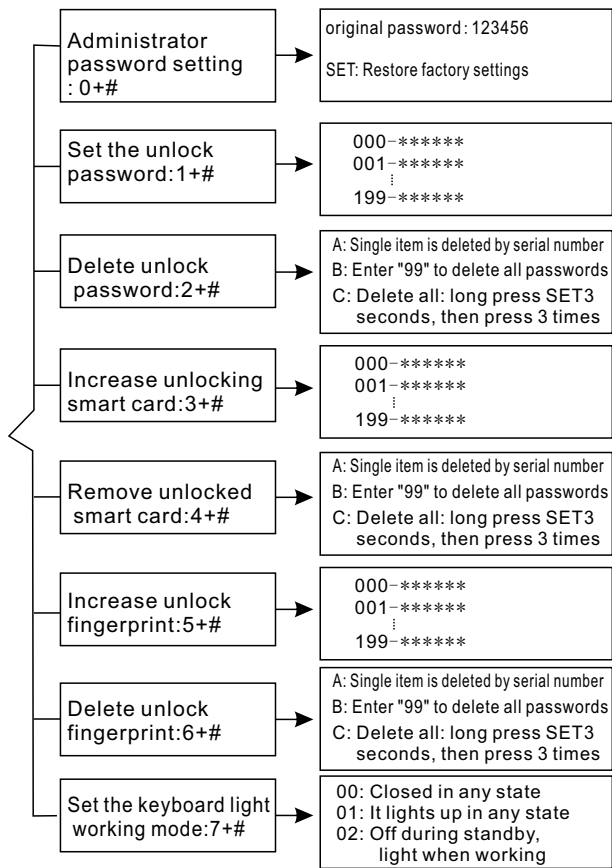

### 4. Instructions

#### Description:

Factory parameter: administrator password 123456; digital maximum can set 200PCS, the maximum number of cards is 200PCS, the maximum fingerprint is 200PCS, (Note: please refer to the physical panel for corresponding function) Note: The password cannot be "000000"

#### 0: Modify the management password:

In standby mode: enter the management password "123456" + "#" to enter the setting mode, Press "0" + "#" to set a new management password, enter the new 6-digit management password and press "#" to confirm and return to the setting mode. Note: If you forget the management password, long press the setting button for 3 seconds, then press the setting button three times in a row, the machine will ring "Bi-Bi-Bi" three times and return to the factory setting state (all data deletion) please be careful Use this feature.

#### 1: Increase the unlock password:

In standby mode: Enter the management password "123456" + "#" to enter the setting mode Press "1" + "#" to increase the unlock password, enter the 3-digit serial number "XXX(000-199)" + "#"; "XXXXXXX" (6-bit unlock password) + "#", machine (long ring Bi One sound, continue to enter the next set of passwords, then press # key to save, (serial number plus one) Press \* to return to the setting mode (or wait 30 seconds to return to standby). Example: Set the password for serial number 001 to 223344 (123456+#+1+#+001+#+223344+#)

## 2: Delete the unlock password

A: In standby mode: enter the management password "123456" + "#" to enter the setting mode Press "2" + "#" to delete the unlock password, enter 3 digits "XX X(000-199)" + unlock password group number + "#", press # key to delete (long ring Bi), press \* key to return to setting mode (or wait 30 seconds to return to standby).

B: In standby mode: enter the management password "123456" + "#" to enter the setting mode Press 2 + "#" to delete the unlock password, and enter "99" + "#" to delete the password.

## 3: Add an IC card

A: In standby mode: enter the management password "123456" + "#" to enter the setting mode Press 3 + "#" to add the IC card, input 3 "XXX (000-199)" unlock card number group number + "#", put the proximity card on the sensing keyboard position, read the card number and successfully sound "B" for a long time, change The next card continues to be added (group number1) press the \* button to return to the setup mode (or wait 30 seconds to return to standby).

B: Press the setting button in standby mode to enter the card-increasing state, and the card can be added. The software will automatically save the card number from 000-199, and then search for the blank position from low to high, and then press the setting button to return to the standby state.

## 4: Delete card number

A: In standby mode: enter the management password "123456" + "#" to enter the setting mode Press "4" + "#" to delete the unlock card number, enter 3 digits "XXX (000-199)" unlock card number group number + "#" delete (long ring B),

B: in standby mode: enter the management password "123456" + "#" enters the setting mode, press "4" + "#" to delete the unlocking card number, put the card to be deleted in the sensing area, and the reading is successful after a long beep. Press the \* button to return to the setup mode (or wait 30 seconds to return to standby).

C: In standby mode: enter the management password "123456" + "#" to enter the setting mode Press "99" + "#" to delete all passwords.

## 5: In standby mode:

enter the management password "123456" + "#" to enter the setting mode Press "5" + "#" to increase the fingerprint, input 3 "XXX(000-199)" fingerprint group number + "#", put your finger in the sensing position, read the fingerprint successfully and save the long ring "Bi", change the next fingerprint to continue to add (group number +1). Press the \* button to return to the setup mode (or wait 30 seconds to return to standby). group number + "#" delete (long ring B),

## 6: In standby mode:

enter the management password "123456" + "#" to enter the setting mode Press 6 + "##" to delete the unlock fingerprint, input 3 digits "XXX(000-199)" fingerprint group number, press # key to delete (long sound B sound), continue to delete the next set of fingerprints, then press # key to save, Press the \* button to return to the setup mode (or wait 30 seconds to return to standby). . Note: Enter "99" to delete all fingerprints.

## 7:Keyboard backlight settings:

In standby mode: enter the management password "123456" + "#" to enter the keyboard light setting mode

"00" + "#" (off)

"01" + "#" (lights up)

"02" + "#" (off during standby, light when working)

## 5.Operating method without keyboard panel

1:Add RDID card/fingerprint. In standby mode, press the SET button, hear Bi, swipe in the card swipe area, complete the card, or press the fingerprint in the fingerprint collection area to complete the card. After the addition is completed, you can click SET. The button returns to standby, or waits 30 seconds to enter standby.

2: Delete the RFID or fingerprint. In the standby state, press and hold the SET button 3S, hear a long beep, then press the button three times, and hear the long beeping "Bi-Bi-Bi" 3, all the data is cleared.

## 6.About the power supply instructions

The machine can be powered in three ways:

1: The indoor unit is powered, and it is necessary to wait for an indoor unit with 5V power supply.

2: External power supply, 12V /  $\geq 1A$

3: Backup battery power supply

## 7.Battery Management Instructions

The maximum current of the rechargeable battery is 50MA, (the indoor unit standby 5V power supply should be greater than 150MA), intelligent charging management. The power backup battery is automatically switched. No manual intervention is required.

Battery management indicator: red charging status, blue backup battery

## 8.Unlocking instructions

There are three ways to unlock.

1: Relay NC, NO, COM unlock mode

2: Pulse lock directly unlocks the power supply without external lock power supply

3: External unlocking module, safer by remote unlocking,

4: The unlock delay time can be adjusted from 2S to 10S, please adjust to the appropriate delay time.

5: When the door button is used, it is installed indoors. When going out from the room, press the door button directly to open the electric lock.

## 9.Product parameters

Camera	CCD/CMOS
View angle	1/3"(120°)                      1/2.7"(140°)
Definition(Hor.)	CVBS800TVL;AHD720P/960P/1080P
LEDs for night	IR LEDs(120°)
Power consumption	200mA max.(10V-13V DC)
Power supplier	Supplied from indoor unit
Operation temp.	-40~+50℃
Installation	Surface/flush mount

### NOTE:

- If it is AHD call panel must be use AHD indoor monitor to correctly decode , otherwise no image display
- If use the exit button function , the indoor monitor when standby state must have 5V power supply